

# Industrial Gas Springs - Gas springs application sheet



Email to: [support@igs Ltd.co.uk](mailto:support@igs Ltd.co.uk)

or Fax to: 020 8646 6594

IGS Technical Support can try to work out the optimised mounting position for gas springs on your application as long as this form and a scaled drawing of the application are sent together.

Because each engineering review takes an average of one hour to work out, we reserve the right to decline applications requests which are not provided with all the information shown on this form.

The quotation and engineering review will be sent to the email address you provide.

Company _____	Contact _____
Address _____	
Telephone number _____	Fax number _____
Email address _____	
How many of these lids/hatches will be made? Short Term: _____ Approximate annual quantity: _____	
Your reference (application name or description, etc...) _____	

Please select the figure that best represents your application and answer the following questions:

<p><b>Starting horizontal</b></p> <p><b>1A</b> <i>box</i></p> <p><b>1B</b> <i>hatch</i></p>	<p><b>Starting vertical</b></p> <p><b>2A</b> <i>kitchen cabinet</i></p> <p><b>2B</b> <i>flush mount</i></p>	<p><b>Falling lid</b></p> <p><b>3A</b> <i>box</i></p> <p><b>3B</b> <i>flush mount</i></p>	<p><b>Start below horizontal</b></p> <p><b>4A</b> <i>tool box</i></p> <p><b>4B</b> <i>window</i></p>
---	---	---	--

Application type:	<input type="checkbox"/> 1A	<input type="checkbox"/> 2A	<input type="checkbox"/> 3A	<input type="checkbox"/> 4A	Weight of lid (W): _____ kg
	<input type="checkbox"/> 1B	<input type="checkbox"/> 2B	<input type="checkbox"/> 3B	<input type="checkbox"/> 4B	Distance from pivot to end of lid (L): _____ mm
Number of springs per lid:	<input type="checkbox"/> 1 or <input type="checkbox"/> 2				Distance from pivot to centre of gravity (C): _____ mm
Starting angle (β): _____ degrees (type 4 only)					Thickness of lid (H): _____ mm
Opening angle (Ø): _____ degrees					Maximum depth of mounting position (G): _____ mm

Please select the statement which best describes what you are trying to achieve:

- When the lid is closed, it should stay closed and when it is open it should stay open, like a car boot.
- The lid should always open automatically even when it is closed. The lid has a lock to keep it closed.
- The gas springs are only used to take some of the weight off. The lid should fall on its own at all times.

Do you require the spring to be mounted:  Inside  Outside  Either

How often will this application be used ? \_\_\_\_\_ (e.g: 2 cycles/hour, once a month, twice a year)

Operating temperature: from \_\_\_\_\_ °C to \_\_\_\_\_ °C

Will the gas springs be exposed to chemicals or humidity ? if yes please detail: \_\_\_\_\_

**Please send a drawing with dimensions attached to this application form**

**Please note: Due to a heavy demand for free application reviews, we can no longer respond to applications which are not supplied with BOTH a completed application form AND a scaled drawing of the application.**



This page is for your reference only. Please consider the environment before you print or fax it.

The term "lid" used on this page refers to the part that the gas spring(s) will be pushing. This "lid" can be simply a flat piece of wood or an assembly of different parts such as a complex lid with an engine.

Your scale drawing should clearly show:

- A - The areas where the gas springs must be fitted
- B - The areas which can block the gas springs (if any)
- C - The exact position of the centre of gravity in relation with the pivot point
- D - How much the lid has to rotate (*in degrees, e.g.: 65 deg., 90 deg., etc...*)

Please let us know if you have a preference for the end fittings (e.g. ball joint, metal eyes, etc...)

We will also need to know:

- The weight of the lid
- How many gas springs you would like on the lid (1 or 2 ?).
- Describe how the lid should behave once the gas springs are fitted

*For example: Manual opening for the first 10 to 30 degrees, then lid should open on its own until it reaches 90 degrees.*

- Will the gas springs will be exposed to difficult environments (e.g.: salt, vibrations) or any other aggressive element such as direct sun radiation, chemicals, temperatures, food or chemical industry...
- How often will the lid be used ? Please keep in mind that gas springs are not suitable for more than 24 cycles per minute.

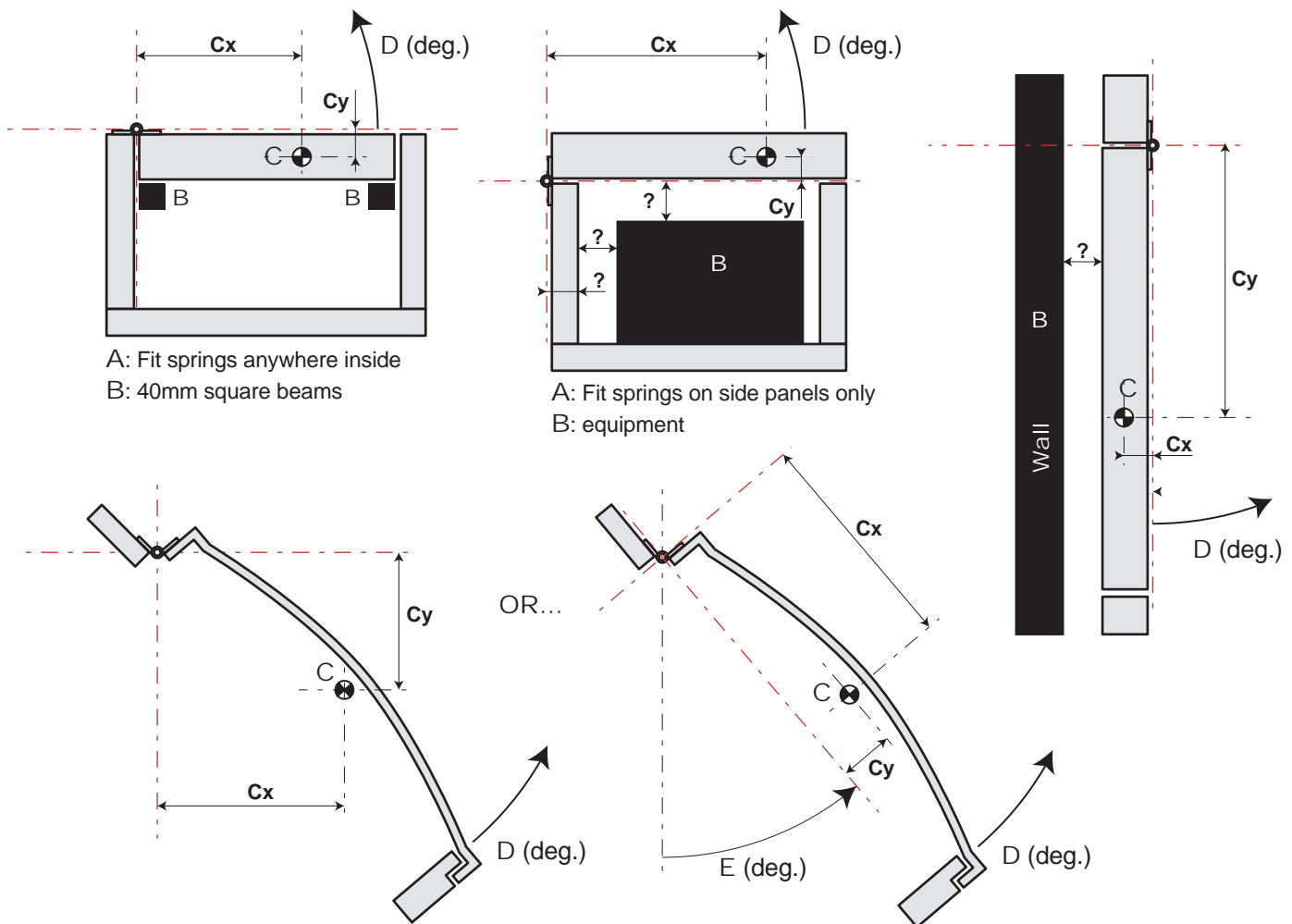

**Important: The engineering reviews are provided by Industrial Gas Springs Ltd (IGS) in good faith. Our reports show the hand forces you can expect when the specified gas springs are fitted exactly as shown on the drawings: no other mounting position and no other gas spring will give you the same results.**

As long as the data provided to IGS is accurate and the gas springs are fitted **exactly as per our recommendations**, the application should work as described on the engineering review. However, whilst Industrial Gas Springs Ltd (IGS) makes every effort to ensure the accuracy of the suggestions, responsibility cannot be accepted for the suitability of the proposals:

IGS does not have control over all parameters involved on this application e.g.: the friction forces, side loads, brackets used, precision of the mounting position, the normal abuse the gas spring will suffer, etc. For this reason, prototypes of the suggested solution must be tested and approved before large quantities are ordered.

